

ELEVATOR GUIDE RAILS



CELIKRAY
ELEVATOR GUIDE RAILS



CELIKRAY
ELEVATOR GUIDE RAILS

Sektörün Yükselen Gücü / Rising power of the sector



CELIKRAY
ELEVATOR GUIDE RAILS



KARABÜK / FABRIKA

ÇELİKOĞLU Demir Çelik Sanayi ve Ticaret Ltd. Şti. 1993 yılında, demir çelik imalatının beşiği olan KARABÜK'de kurulmuştur. Demir çelik sektöründe hizmet veren firmamız, çalışmalarını standartlara uymayı ve tavizsiz kalite anlayışını ilke edinerek sürdürmektedir. 25000 m²'si kapalı toplamda 50000 m² alan üzerine kurulu olan fabrikamız, 7000 Ton/8 saat aylık asansör ray üretimi, yıllık ise 180.000 ton sıcak haddeleme imkanına sahiptir. Hali hazırda 30 ülkeye ihracat yapan çelik sektöründeki tecrübesi ve uzman kadrosunu 1998 yılında ASANSÖR RAYI imalatına yönlendirerek ÇELİKRAY markası ile kısa sürede Türkiye asansör sektöründe büyük mesafe kat etmiştir. Asansör sektörüne kaliteli mamülleri ile hizmet sunan firmamız, 2001 yılı itibari ile yurt dışına ihracatlarını başlatmış ve devam etmektedir.

Yurt içindeki müşterilerimize ve potansiyel müşteri grubuna ulaşip ürünlerimize ve potansiyel müşteri grubuna ulaşip ürünlerimizi satmak üzere hedef kitlemiz ile ilişkilerimizi her zamankinden daha üst düzeyde olmaktadır. Bölgesel programlar oluşturup yurt içi ve yurt dışı satış yönetimimize uygun müşteri memnuniyetini kurumumuzun geleceğe yönelik olarak yaptığı yatırımların güvencesi olarak görmekte ve bu doğrultuda hareket etmekteyiz. Müşterilerimize ulaşabilme araçlarını değerlendirmek, yeni müşteri kazanılması çalışmalarında aktif rol almak için pazar analizleri yapılması kapsamında, araştırma ve geliştirme faaliyetlerimize devam etmekteyiz. Amacımız ürünlerimizle ilgili olarak dünya genelinde sorunsuz iletişimle Pazar payımızı arttırmaktır.

Çelikoğlu Iron and Steel Corporation was established in Karabük which is the home town of iron and steel production. Our company serves in iron and steel sector and continuous its operation by following the standards and not leaving the quality ideologies. Our factory is located 50.000 m² area of which 25.000 m² is closed. As CELİKRAY, we have 7.000 tons of elevator rail production capacity monthly and 180.000 hot rolling capacity annually. We export our products to more than 30 countries in all over the world for the time being. In 1998 the company has started to direct its specialization in steel sector and experienced staff to the elevator rail production. The brand name of ÇELİKRAY has become well-known in Turkish elevator sector in a few years. Our company supplies qualified products to the elevator sector and has started exporting since 2001. In order to reach the customers and aimed groups in the domestic market and sell our products we need to set more close relation with our aimed groups. Domestic and international customer pleasure are seen as the guarantee of the following investments. We continue doing research and development activities to analyze the instruments for reaching our customers and to find out new customers by conducting market analyzes.



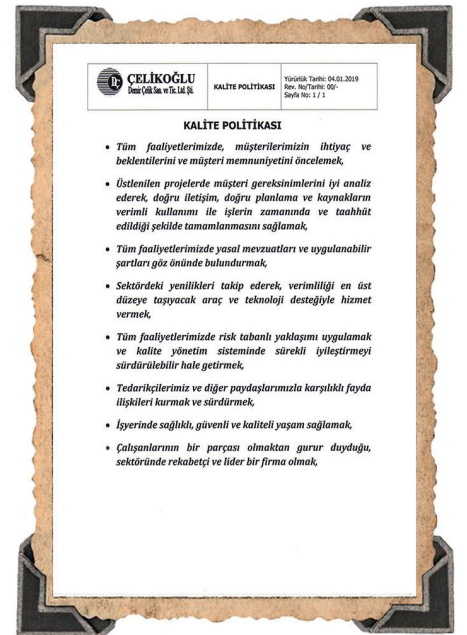

MİSYONUMUZ / MISSION

Müşteri ihtiyaç ve beklentilerini en iyi şekilde anlayarak onlara en doğru kanaldan en uygun çözümleri sunan yaygın satış ağı ve geniş ürün yelpazesi ile en hızlı en ekonomik ve en kaliteli şekilde ulaştıran etik değerlerin ve sorumluluğun bilincinde olarak dünya standartlarında ve kalitesinde faaliyetini sürdüren müşteri memnuniyetini her şeyden üstün tutan bir şirket olmayı, mevcut durumunu sürekli geliştirerek demir çelik sektöründe ulusal ve uluslararası pazarda en iyi olmaktır. İleri teknoloji bilgisi, dinamik ve yetkin kadrosuyla, girişimci, sağduyulu, müşteri odaklı yaklaşımıyla "demir çeliğin ve asansör kılavuz ray üretimi ile asansör sektörünün mükemmel üretim markası olmak"

To present optimum solutions for the clients by understanding customer needs and expectations through our wide sales network and wide product portfolio. To be a company seeing customer satisfaction as first priority and acting in world standards being conscious of ethical values and responsibilities. To be the best in iron-steel sector in national&international level by developing itself continuously. To be a perfect brand in elevator rail production with its high technology, dynamic and experienced staff, customer oriented approach.

VİZYONUMUZ / VISION

Türkiye'de ve Dünya'nın her yerinde yaygın, güvenilir ve aynı kalitede hizmet sunan herkezin vazgeçilmezi müşterileri ve insan kaynaklarını en değerli ve aktif olarak kabul eden köklü geçmişine göre devamlı ve sürkli olarak fark, değer ve avantaj sağlayan saygın aynı zamanda müşterilerinin çalışmaktan huzur ve mutluluk duyduğu bir şirket olmayı amaçlamaktadır.

To be a respectable company who serves reliable, widespread and with the same quality both in Turkey and in the all over the world by accepting human resources active and the most important value. To be a company which continuously creates difference, values and advantage for its clients who are always happy to deal with CELIKRAY.

İHRACAT / EXPORT

Türkiye asansör sektörüne kaliteli mamulleri ile hizmet sunan Çelikray, 2001 yılı itibari ile güç potansiyelini ülke dışında da değerlendirmek üzere ihracata başlamış, kısa sürede elde ettiği olumlu gelişmelerle ülke ekonomisine katkıda bulunarak ihracat payını arttırmak için faaliyetlere devam etmektedir. Bir dünya işletmesi olma yolunda üretimimizi, satış ve karımızı artırmak, iç pazara bağlı büyümenin yanında, geniş bir vizyonla dünya ölçeğinde büyüme şansını elde etmek, dünya pazarlarında "Made in Turkey" damgalı ürünlerin daha yoğun yer almasını sağlamak, genç bir nüfusu olan ülkemizin yatırım ve istihdam olanaklarını artırarak sosyal sorumluluk sahibi kurum kimliğini ortaya koymak, ihracat payımızı artırmak suretiyle ülkemize döviz akışına katkıda bulunmak, uluslararası arenada bilgi, teknoloji ve işletme modellerinde meydana gelen gelişmeleri yakından takip edip, yenileşmeyi ve güncelliği sağlayarak dünya markası olma yolunda hızla ilerlemekte ve halen 26 ayrı ülkeye ürünlerini ihraç etmektedir.

ÇELİKRAY has been supplying qualified products in the domestic market since its established. By 2001, the company has started exporting to use its power potential in the international market. In a short time the company gained positive developments since then the company has been trying to increase its exporting and supply positive effects to the state economy. We want to become an international corporation, increase our turnover and profit and make well known our brand name in the world by writing "Made in Turkey" on our products. We will supply working opportunities to the people in our country and make new investments for the development of our company. We will increase exporting amount so that foreign currency will come more to our country. We will follow all the new technological and management system that are conducted in the World. We will become a world brand by exporting its products all over the world.





CELIKRAY
ELEVATOR GUIDE RAILS



İHRACAT YAPTIĞIMIZ ÜLKELER
COUNTRIES EXPORTED





T45

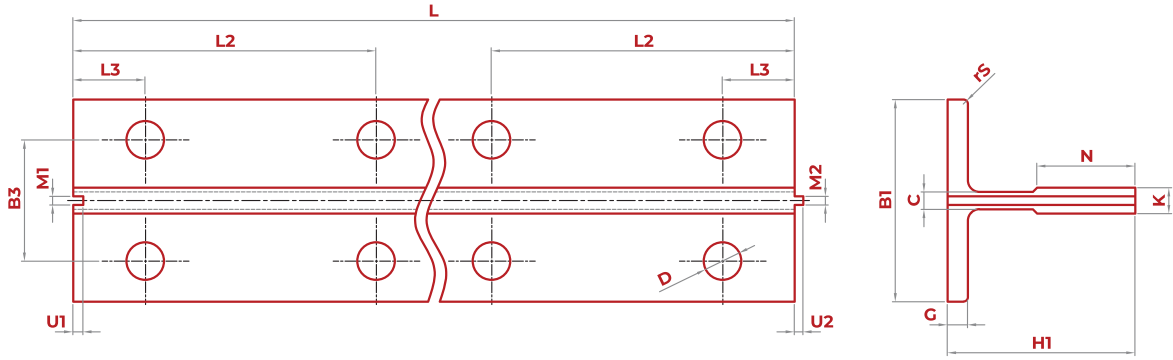

T45/A-45x45x5mm.

ASANSÖR KILAVUZ RAYI / ELEVATOR GUIDE RAIL

BOYUTLAR / DIMENSIONS

KOD / NO	EBAT / SIZE	L	B1	H1	K	N	C	G	rS	M1	M2	U1	U2	B3	L3	L2	D
		TOLERANSLAR / TOLERANCES															
		±2	±1	±0,20	±0,15			±0,5		+0,06	-0,06	±0,10	±0,10	±0,20	±0,20	±0,20	
T45/A	45x45x5 mm.	5000	45	45	5	27	4	5	1	2	1,95	2,5	2	25	15	65	9

TEKNİK ÖZELLİKLER / TECHNICAL CHARACTERISTICS

KOD / NO	EBAT / SIZE	S	Q	E	Lxx	Wxx	İxx	Lyy	Wyy	İyy
		cm ²	Kg/m	cm	cm ⁴	cm ³	cm	cm ⁴	cm ³	cm
T45/A	45x45x5 mm.	4,25	3,34	1,31	8,08	2,53	1,38	3,84	1,71	0,95

45x45x5 mm.

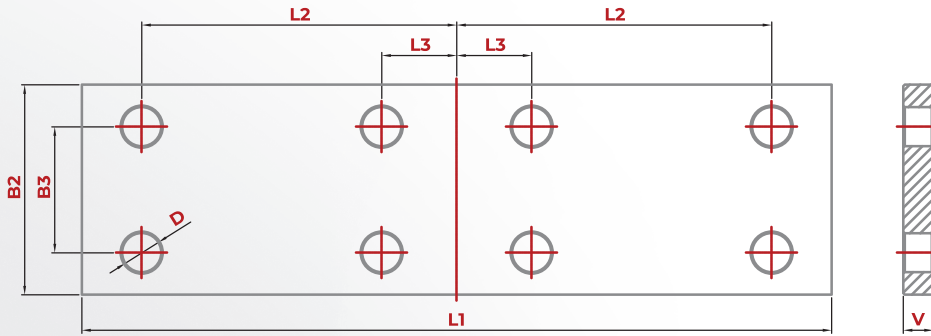

DELİKLER VE BAĞLANTI PARÇALARI / HOLES and FISHPLATES

KOD / NO	EBAT / SIZE	D	L1	L2	L3	V	B2	B3	CİVATA TAKIMI / SCREW SETS	TIRNAK / T CLIPS
		TOLERANSLAR / TOLERANCES								
		+3	±0,20	±0,20	+3			±0,20	UNI 5727 DIN 601	DIN 7168
T45		9	160	65	15	8	50	25	M8x25 / M8x30	M1

T50

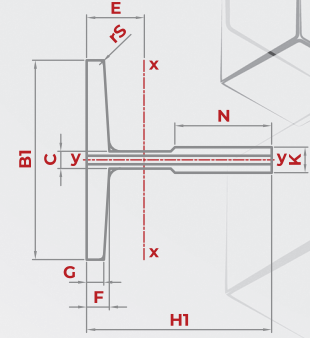
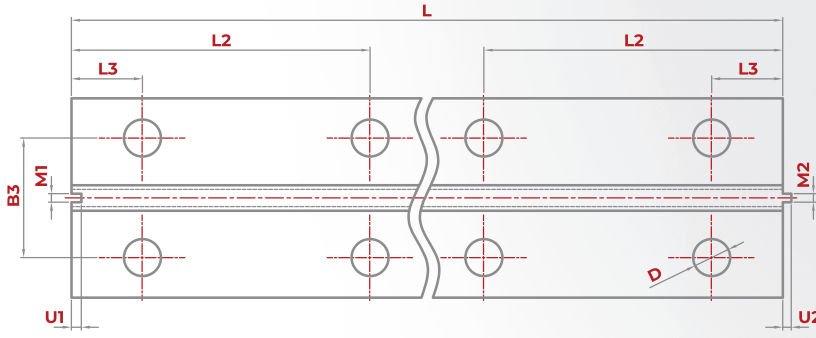

T50/A-50x50x5mm.

ASANSÖR KILAVUZ RAYI / ELEVATOR GUIDE RAIL

BOYUTLAR / DIMENSIONS

KOD / NO	EBAT / SIZE	L	B1	H1	K	N	C	G	F	rS	M1	M2	U1	U2	B3	L3	L2	D
		TOLERANSLAR / TOLERANCES																
		±2	±1	±0,20	±0,15						+0,06	-0,06	±0,10	±0,10	±0,20	±0,20	±0,20	
T50/A	50x50x5 mm.	5000	50	50	5	27	4	4,5	5,5	1	2	1,95	2,5	2	30	25	75	9

TEKNİK ÖZELLİKLER / TECHNICAL CHARACTERISTICS

KOD / NO	EBAT / SIZE	S	Q	E	Lxx	Wxx	İxx	Lyy	Wyy	İyy
		cm ²	Kg/m	cm	cm ⁴	cm ³	cm	cm ⁴	cm ³	cm
T50/A	50x50x5 mm.	4,75	3,73	1,43	11,24	3,15	1,54	5,25	2,1	1,05

50x50x5 mm.

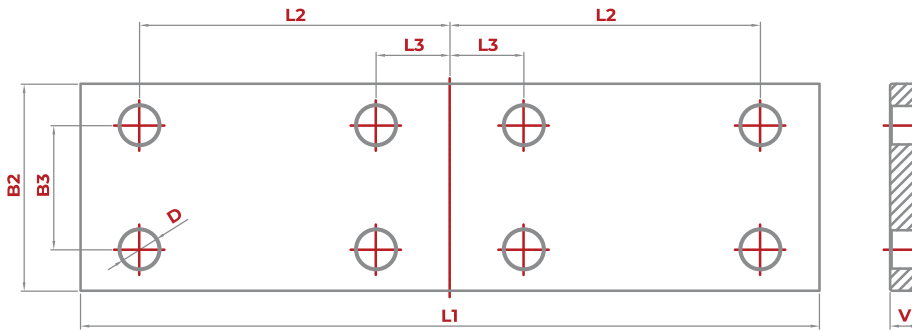

DELİKLER VE BAĞLANTI PARÇALARI / HOLES and FISHPLATES

KOD / NO	EBAT / SIZE	D	L1	L2	L3	V	B2	B3	CİVATA TAKIMI / SCREW SETS	TIRNAK / T CLIPS
		TOLERANSLAR / TOLERANCES								
		+3	±0,20	±0,20	+3			±0,20	UNI 5727 DIN 601	DIN 7168
T50		9	200	75	25	8	50	30	M8x25 / M8x30	M1





T70

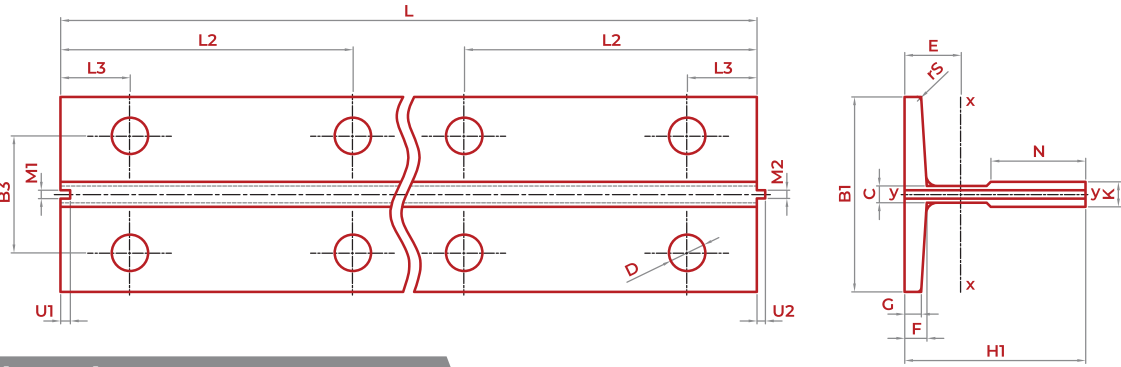

T70/A / T70/B-70x65x9mm.

ASANSÖR KILAVUZ RAYI / ELEVATOR GUIDE RAIL

BOYUTLAR / DIMENSIONS

KOD / NO	EBAT / SIZE	L	B1	H1	K	N	C	G	F	rS	M1	M2	U1	U2	B3	L3	L2	D	D1	I	H
		TOLERANSLAR / TOLERANCES																			
		±2	±1,5	±0,10	+0,10	+3		±0,75	±0,75		+0,06	-0,06	±0,10	±0,10	±0,20	±0,20	±0,20			+3	±0,10
T70/A	70x65x9 mm.	5000	70	65	9	34	6	6	8	1,5	3	2,97	3,5	3	42	25	105	13			
T70/B	70x65x9 mm.	5000	70	65	9	34	6	6	8	1,5	3	2,97	3,5	3	42	25	105	13	140	64	

TEKNİK ÖZELLİKLER / TECHNICAL CHARACTERISTICS

KOD / NO	EBAT / SIZE	S	Q	E	Lxx	Wxx	ixx	Lyy	Wyy	iyy
		cm ²	Kg/m	cm	cm ⁴	cm ³	cm	cm ⁴	cm ³	cm
T70/A	70x65x9 mm.	9,40	7,38	2,03	40,95	9,17	2,09	18,86	5,39	1,42
T70/B	70x65x9 mm.	9,40	7,37	2,03	40,95	9,16	2,08	18,86	5,38	1,41

70x65x9 mm.

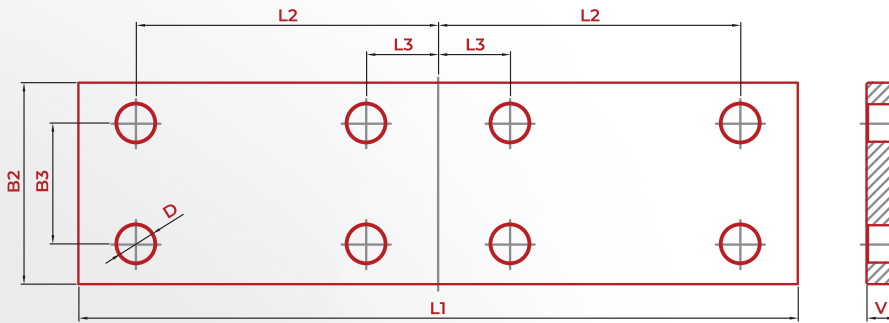

DELİKLER VE BAĞLANTI PARÇALARI / HOLES and FISHPLATES

KOD / NO	EBAT / SIZE	D	L1	L2	L3	V	B2	B3	CİVATA TAKIMI / SCREW SETS	TIRNAK / T CLIPS
		TOLERANSLAR / TOLERANCES								
		+3	±0,20	±0,20	+3			±0,20	UNI 5727 DIN 601	DIN 7168
T70		13	250	105	25	10	70	42	M12x35	M2

T82

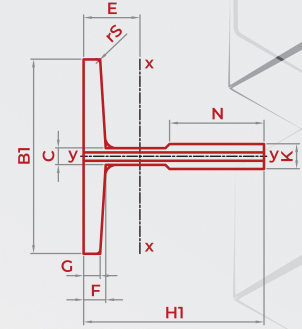
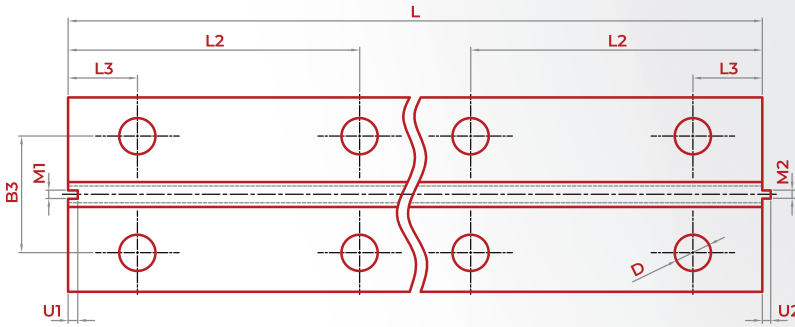

T82/A / T82/B-82x68x9mm.

ASANSÖR KILAVUZ RAYI / ELEVATOR GUIDE RAIL

BOYUTLAR / DIMENSIONS

KOD / NO	EBAT / SIZE	L	B1	H1	K	N	C	G	F	rS	M1	M2	U1	U2	B3	L3	L2	D	D1	I	H
		TOLERANSLAR / TOLERANCES																			
		±2	±1,5	±0,10	+0,10	+3		±0,75	±0,75		+0,06	-0,06	±0,10	±0,10	±0,20	±0,20	±0,20			+3	±0,10
T82/A	82x68x9 mm.	5000	82	68	9	34	7,5	6	8,25	3	3	2,97	3,5	3	50,8	27	81	13	26		
T82/B	82x68x9 mm.	5000	82	68	9	34	7,5	6	8,25	3	3	2,97	3,5	3	50,8	27	81	13	-	120	67

TEKNİK ÖZELLİKLER / TECHNICAL CHARACTERISTICS

KOD / NO	EBAT / SIZE	S	Q	E	Lxx	Wxx	ixx	Lyy	Wyy	iyy
		cm ²	Kg/m	cm	cm ⁴	cm ³	cm	cm ⁴	cm ³	cm
T82/A	82x68x9 mm.	10,91	8,56	1,99	49,31	10,27	2,12	30,17	7,36	1,66
T82/B	82x68x9 mm.	10,91	8,56	1,99	49,31	10,27	2,12	30,17	7,36	1,66

82x68x9 mm.

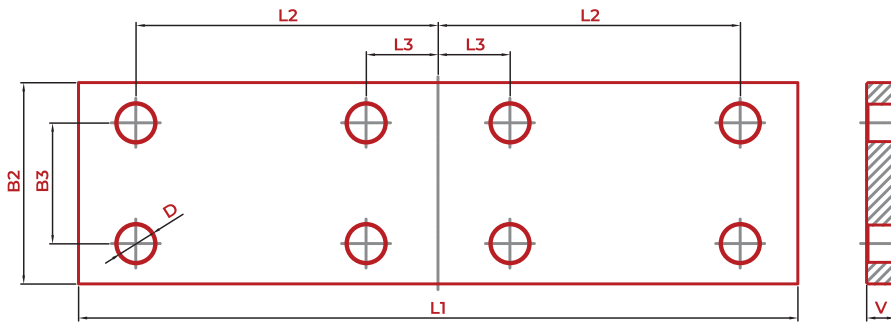

DELİKLER VE BAĞLANTI PARÇALARI / HOLES and FISHPLATES

KOD / NO	EBAT / SIZE	D	L1	L2	L3	V	B2	B3	CİVATA TAKIMI / SCREW SETS	TIRNAK / T CLIPS
		TOLERANSLAR / TOLERANCES								
		+3	±0,20	±0,20	±0,20	+3		±0,20	UNI 5727 DIN 601	DIN 7168
T82		13	216	81	27	10	80	50,8	M12x35	M2





T89

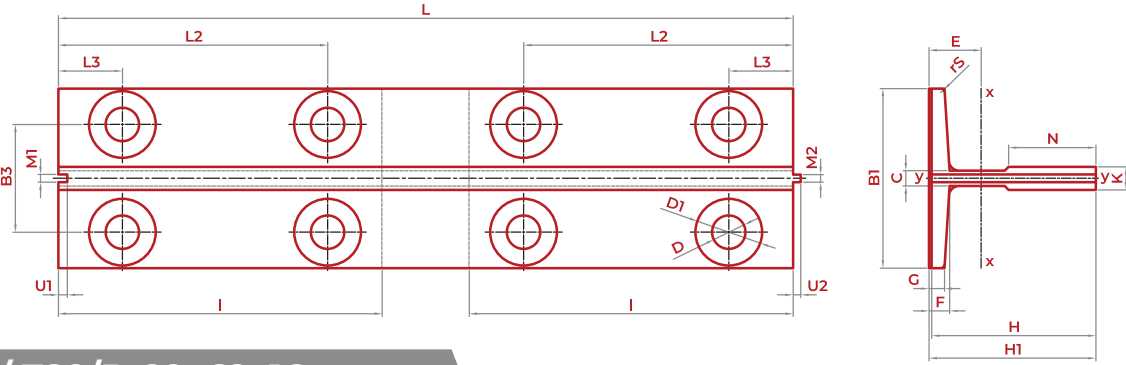

T89/A / T89/B-89x62x16mm.

ASANSÖR KILAVUZ RAYI / ELEVATOR GUIDE RAIL

BOYUTLAR / DIMENSIONS

KOD / NO	EBAT / SIZE	L	B1	H1	K	N	C	G	F	rS	M1	M2	U1	U2	B3	L3	L2	D	D1	I	H
		TOLERANSLAR / TOLERANCES																			
		±2	±1,5	±0,10	+0,10	+3		±0,75	±0,75		+0,06	-0,06	±0,10	±0,10	±0,20	±0,20	±0,20			+3	±0,10
T89/A	89x62x16 mm.	5000	89	62	16	34	10	7,9	11,1	3	6,4	6,37	7,14	6,35	57,2	38,1	114,3	13	26		
T89/B	89x62x16 mm.	5000	89	62	16	34	10	7,9	11,1	3	6,4	6,37	7,14	6,35	57,2	38,1	114,3	13	26	156	61

TEKNİK ÖZELLİKLER / TECHNICAL CHARACTERISTICS

KOD / NO	EBAT / SIZE	S	Q	E	Lxx	Wxx	İxx	Lyy	Wyy	İyy
		cm ²	Kg/m	cm	cm ⁴	cm ³	cm	cm ⁴	cm ³	cm
T89/A	89x62x16 mm.	15,77	12,38	2,03	59,83	14,35	1,95	52,41	11,78	1,82
T89/B	89x62x16 mm.	15,77	12,38	2,03	59,83	14,35	1,94	52,41	11,78	1,82

89x62x16 mm.

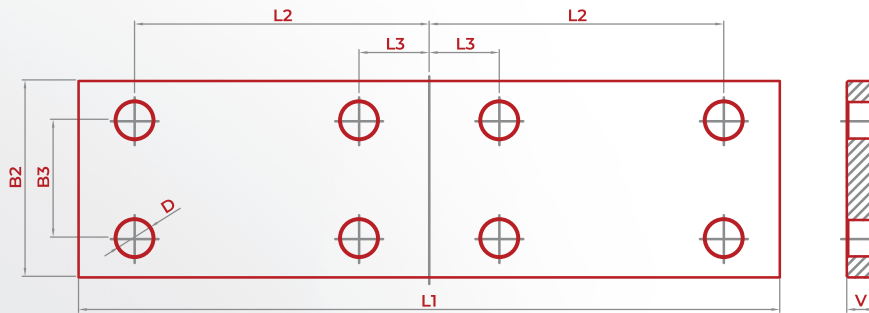

DELİKLER VE BAĞLANTI PARÇALARI / HOLES and FISHPLATES

KOD / NO	EBAT / SIZE	D	L1	L2	L3	V	B2	B3	CİVATA TAKIMI / SCREW SETS	TIRNAK / T CLIPS
		TOLERANSLAR / TOLERANCES								
		+3	±0,20	±0,20	+3			±0,20	UNI 5727 DIN 601	DIN 7168
T89		13	305	114,3	38,1	13	90	57,2	M12x30 / M12x40	M3

T90

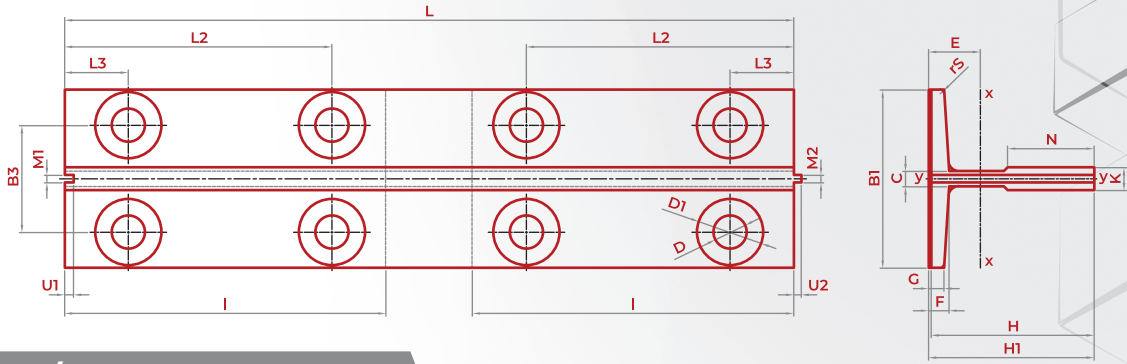

T90/A / T90/B-90x75x16mm.

ASANSÖR KILAVUZ RAYI / ELEVATOR GUIDE RAIL

BOYUTLAR / DIMENSIONS

KOD / NO	EBAT / SIZE	L	B1	H1	K	N	C	G	F	rS	M1	M2	U1	U2	B3	L3	L2	D	D1	I	H
		TOLERANSLAR / TOLERANCES																			
		±2	±1,5	±0,10	+0,10	+3		±0,75	±0,75		+0,06	-0,06	±0,10	±0,10	±0,20	±0,20	±0,20			+3	±0,10
T90/A	90x75x16 mm.	5000	90	75	16	42	10	8	10	4	6,4	6,37	7,14	6,35	57,2	38,1	114,3	13	26		
T90/B	90x75x16 mm.	5000	90	75	16	42	10	8	10	4	6,4	6,37	7,14	6,35	57,2	38,1	114,3	13	26	156	74

TEKNİK ÖZELLİKLER / TECHNICAL CHARACTERISTICS

KOD / NO	EBAT / SIZE	S	Q	E	Lxx	Wxx	ixx	Lyy	Wyy	iyy
		cm ²	Kg/m	cm	cm ⁴	cm ³	cm	cm ⁴	cm ³	cm
T90/A	90x75x16 mm.	17,25	13,54	2,61	102,0	20,86	2,43	52,48	11,66	1,74
T90/B	90x75x16 mm.	17,25	13,54	2,61	102,0	20,86	2,43	52,48	11,66	1,74

90x75x16 mm.

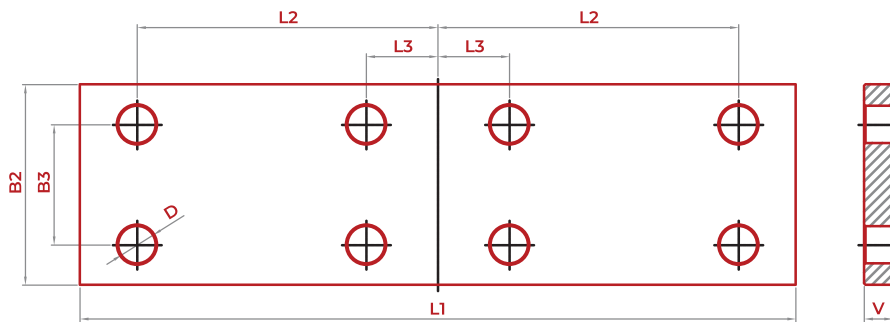

DELİKLER VE BAĞLANTI PARÇALARI / HOLES and FISHPLATES

KOD / NO	EBAT / SIZE	D	L1	L2	L3	V	B2	B3	CİVATA TAKIMI / SCREW SETS	TIRNAK / T CLIPS
		TOLERANSLAR / TOLERANCES								
		+3	±0,20	±0,20	+3			±0,20	UNI 5727 DIN 601	DIN 7168
T90		13	305	114,3	38,1	13	90	57,2	M12x30 / M12x40	M3





T125

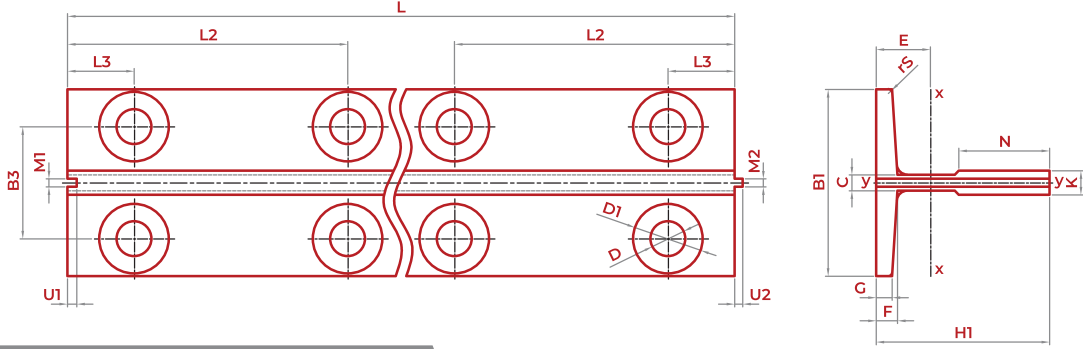

T125/B -125x82x16mm.

ASANSÖR KILAVUZ RAYI / ELEVATOR GUIDE RAIL

BOYUTLAR / DIMENSIONS

KOD / NO	EBAT / SIZE	L	B1	H1	K	N	C	G	F	rS	M1	M2	U1	U2	B3	L3	L2	D	D1	I	H
		TOLERANSLAR / TOLERANCES																			
		±2	±1,5	±0,10	+0,10	+3		±0,75	±0,75		+0,06	-0,06	±0,10	±0,10	±0,20	±0,20	±0,20			+3	±0,10
T125/B	125x82x16 mm.	5000	125	82	16	42	10	9	12	4	6,4	6,37	7,14	6,35	79,4	38,1	114,3	17	33	156	81

TEKNİK ÖZELLİKLER / TECHNICAL CHARACTERISTICS

KOD / NO	EBAT / SIZE	S	Q	E	Lxx	Wxx	ixx	Lyy	Wyy	iyy
		cm ²	Kg/m	cm	cm ⁴	cm ³	cm	cm ⁴	cm ³	cm
T125/B	125x82x16 mm.	22,82	17,91	2,43	151,0	26,16	2,57	159,1	25,46	2,64

125x82x16 mm.

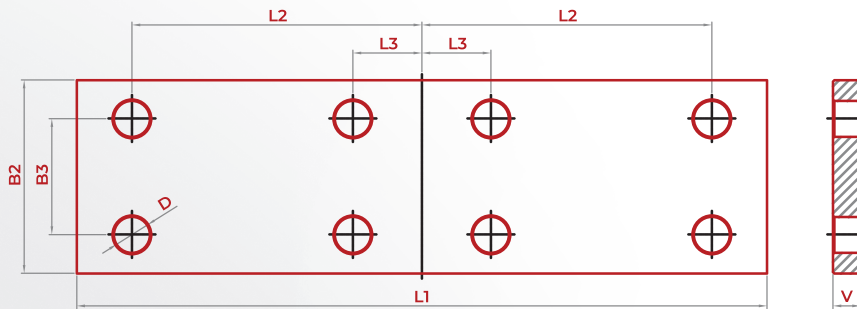

DELİKLER VE BAĞLANTI PARÇALARI / HOLES and FISHPLATES

KOD / NO	EBAT / SIZE	D	L1	L2	L3	V	B2	B3	CİVATA TAKIMI / SCREW SETS	TIRNAK / T CLIPS
		TOLERANSLAR / TOLERANCES								
		+3	±0,20	±0,20	+3			±0,20	UNI 5727 DIN 601	DIN 7168
T125		17	305	114,3	38,1	18	130	79,4	M16x50	M4

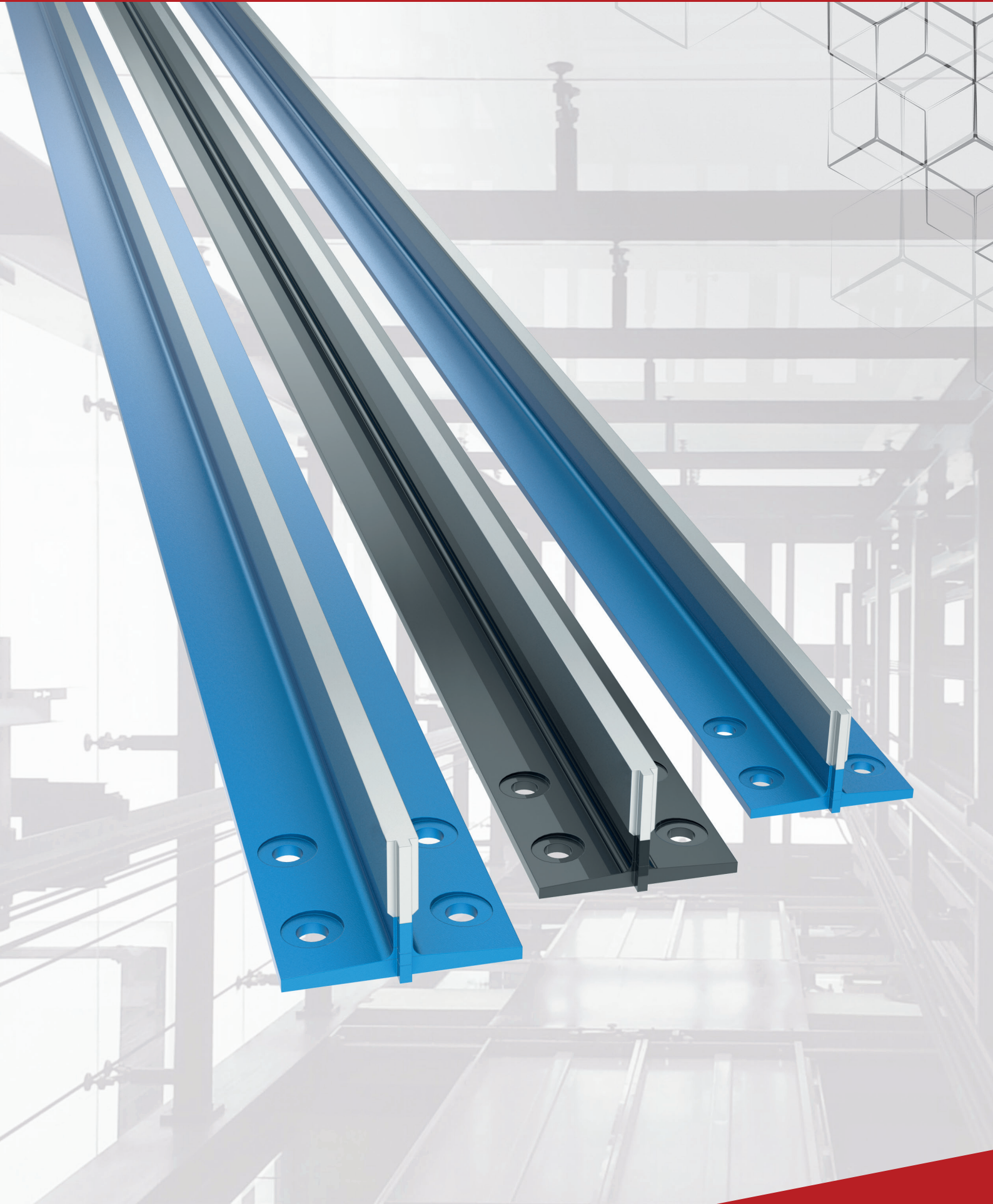



CELİKRAY
TÜRKİYE'NİN
İKİNCİ 500 BÜYÜK SANAYİ
KURULUŞU
2020



HEDEF
İLK 500



CELİKRAY
ELEVATOR GUIDE RAILS



www.celikray.com



CELIKRAY
ELEVATOR GUIDE RAILS

Sektörün Yükselen Gücü / Rising power of the sector



CELİKRAY
ASANSÖR KILAVUZ RAYLARI

FABRİKA
ÇELİKOĞLU DEMİR ÇELİK SAN. VE TİC. LTD. ŞTİ.
Kale Köyü Organize San. Bölgesi Mevkii Safran Sk. No :7/1
Merkez / KARABÜK Tel: 0370 415 78 00 Fax: 0370 415 78 05

KONYA ŞUBE
ÇELİKOĞLU DEMİR ÇELİK SAN. VE TİC. LTD. ŞTİ.
Kobisan 3 San. Sitesi Fevzi Çakmak Mh. 10753 Sk. C Blok No:30/C
Karatay / KONYA Tel: 0332 350 18 28 Fax: 0332 350 99 96
mail@celikray.com - www.celikray.com

İSTANBUL ŞUBE
ÇELİKOĞLU DEMİR ÇELİK SAN. VE TİC. LTD. ŞTİ.
Kordonboyu Mahallesi Ankara Caddesi No:147 DAP Yapı
İSTMARİNA No:145 B Blok K:28 D:348 Kartal İSTANBUL
Tel: 0216 504 37 01 Fax: 0216 504 37 03
istanbul@celikray.com